









List of Parts

Parts	Quantity	
1. Wall Mounted Base	1	
2. Inside Pulley	1	
3. Outside Pulley	1	
4. Wings	5	
5. Screws (4x20mm)	20	
6. Black Screws (4x50mm)	3	
7. Anchors	3	
8. Cap	1	
9. Spacers	3	

Tools Needed

- Phillips head screwdriver
- Pencil
- Drill with ¼" drill bit
- Hammer

Note: Drill with Phillips head drill bit is much faster than a screwdriver to assemble the product, but use caution to not over tighten the screws which could result in cracking the wood.

Do not tighten or adjust anything that is not listed in the instructions.
Do not attempt to operate the product until you have completed through Step 6 of the guide.

Step 1 Assembling the inside layer

- The **inside** layer is made up of 1 pulley + 5 wings + 20screws (No.5).
- Connect each wing to the **inside** pulley. Each hole is numbered, simply match up the numbers on the wing and pulley and then attach using screws (No.5).

We recommend laying the pulley flat on a soft surface while attaching each wing to avoid scuffing. Make sure to grip the pulley (be careful with wings as they are fragile) while you connect the wings and start with the outside holes to make the process easier.

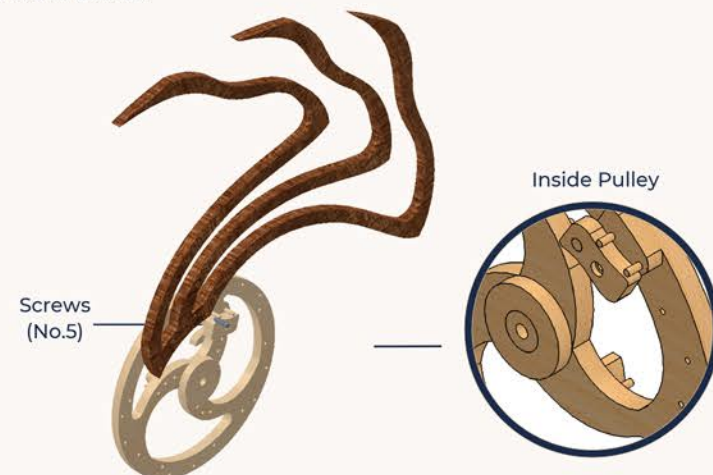

Step 2 Assembling the outside layer

- The **outside** layer is made up of 1 pulley + 5 wings + 20screws (No.5).
- Connect each wing to the **outside** pulley. Each hole is numbered, simply match up the numbers on the wing and pulley and then attach using screws (No.5).

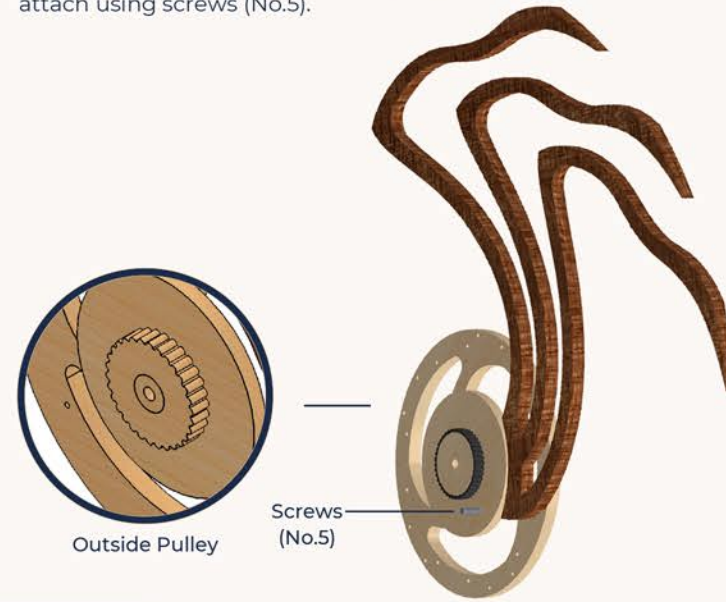

Step 3 Find a good wall location to mount your Mandala

- Bring one of the assembled layers to find your wall location and size up the space.
- Try to mount it at an eye level of your desired space to get the best effect. We recommend a well-lit room that has lighting above it to avoid shadows and to appreciate the visual effect.
- Use a pencil to mark approximately the center of your chosen wall spot. This will make your next step easier when wall mounting the base.

Step 4 Mounting the base to the wall

- Bring the paper template included to the wall spot you marked (the paper template is shaped just like the wall mounted base). Using a pencil, mark the 3 holes through the paper template. Make sure to position the paper template the same way as the next illustration to ensure your base is mounted the right way up.
- Using a Drill with ¼" drill bit, drill carefully through each marking and then use the hammer to tap an anchor (No.7) into each hole.
- After all 3 anchors are tapped in, place the base over the anchors and use black screws (No.6) to secure the base to the wall.

Follow Next Steps on Page 3

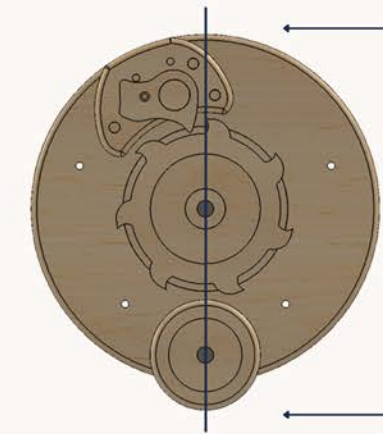

Important: Base must be mounted level as shown here so it will operate correctly.

Step 5 Connecting the layers to the base

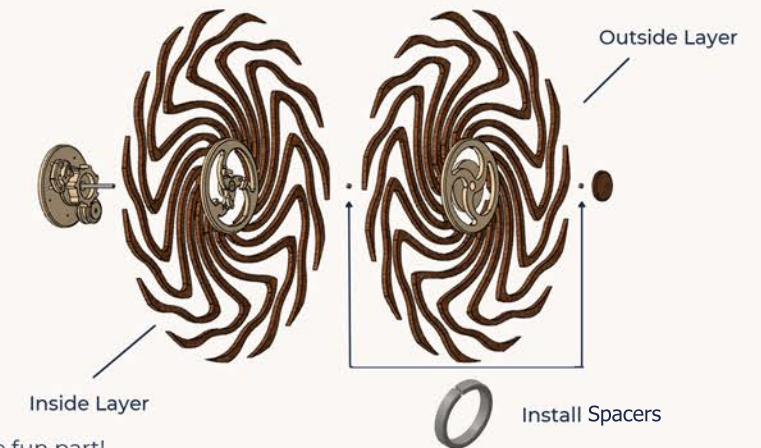

Now for the fun part!

- First, slide the **inside** layer onto the metal pole coming out from the base. Look back at step 1 to make sure you're using the right layer and that it's facing the right direction, you can tell which side is the front because you won't be able to see the screws attaching the wings to the pulley.
- Add 2 Spacers (No.9) onto the metal pole which will act as a separator for the two layers.
- Try spinning the tube if it's difficult to get past the threading on the metal pole.
- Next slide the **outside** layer onto the metal pole. There is a gear on the back of the outside layer and 3 small pieces on the front of the **inside** layer. Use your fingers to lift the 3 small pieces and let them rest on the gear.

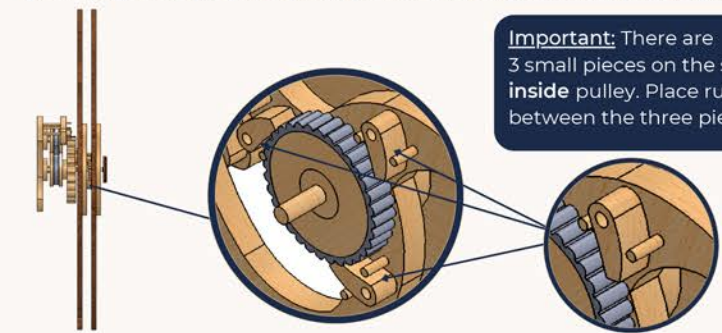

Important: There are 3 small pieces on the surface of the **inside** pulley. Place rubber gear in between the three pieces.

- Last, add 1 Spacers (No.9) and attach the cap (No.8) by screwing it onto the threading of the metal pole.

Voila, you have completed assembly and can now move on to getting it moving (Next Page).

Step 6 Start-up and Usage

- Mandala gets its power from a metal coil at the back of the unit. The run time is based on how many times you wind up the metal coil.
- To wind up, grip the **inside** and **outside** pulleys and rotate clockwise. Fully wound = approximately **35** turns which will provide about **3** hours of run time. Keep in mind after you wind it up, it will run for the full duration. **Slow down winding after about 20-25 turns. If you wind too quickly when the metal coil runs out, you risk damaging the product!**
- After winding up, gently grip the wings (both layers) and spin clockwise being careful not to spin too hard. This will cause the layers to "catch" and it will begin operating on its own.

Winding Up



Getting It Started



Note: Because this is a mechanically powered design, you will hear soft contact between the wood components during operation. This is normal and not a defect of the product.

Caution: Be careful not to hurt your fingers when winding. Also do not wind too quickly to avoid damaging the coil. Never attempt to lift the trigger at the back which acts as a stopper from the coil unwinding. This could lead to the product breaking and more importantly injury!

Sit back, relax and enjoy the experience!

CARE & USE

1. Dust or wipe down the product periodically (we recommend at least once every few months). This will keep it looking fresh and beautiful but more importantly will prevent dust from getting inside the mechanical parts.
2. Try to take a few minutes out of your day to focus on Ripple in motion. The rhythms of motion can calm and reset your mind, allowing you to practice mindfulness or simply make you feel more relaxed.
3. Consider adding other home decor accents around Ripple to create a calming zone. For example, floor plants, subtle wall accents, or lighting.

Problems or need help?

Contact us via Whatsapp: (+84) 868 973 336 Kinetic Sculpture Support

Kinetic Wall Decor

Instruction Manual